

Stainless steel round cylinders with techno-polymer end caps (to ISO 6432 standard for $\varnothing 16 \div 25$)

series UP

1

DESCRIPTION

Cylinders series "UP" are born as technological efficient reply to the always new needs of different industrial fields. They are available from $\varnothing 16$ to $\varnothing 50$ among which $\varnothing 16 \div 25$ comply with ISO 6432 standard. These actuators set themselves as a valid yet economic alternative to cylinders completely made in stainless steel, in many "special" applications (as for example food, chemical and pharmaceutical industry...) and/or aggressive environments. In fact, the peculiar feature of this series is represented by the material used for the realization of the end caps: it's a special techno-polymer that assures adequate mechanical properties.



TECHNICAL DATA

Operating pressure	1 \div 10 bar
Working temperature	0 \div +70 °C (- 20 °C with dry air)
Fluid	Filtered, unlubricated or continuous lubricated compressed air
Versions	Double acting, Single acting front spring, Single acting rear spring, through rod
Bore	$\varnothing 16, 20, 25, 32, 40, 50$
Port size	$\varnothing 16 = M5$ $\varnothing 20 \div 32 = G1/8$ $\varnothing 40 - 50 = G1/4$
Standard strokes (mm)	10, 25, 50, 75, 80, 100, 125, 150, 160, 175, 200, 250, 300, 350, 400, 450, 500
Max strokes (mm)	$\varnothing 16 = 250$ $\varnothing 20 \div 50 = 1000$
Max strokes single act. (mm)	$\varnothing 16 \div 50 = 50$

SPRING THEORETICAL TRACTIVE FORCE

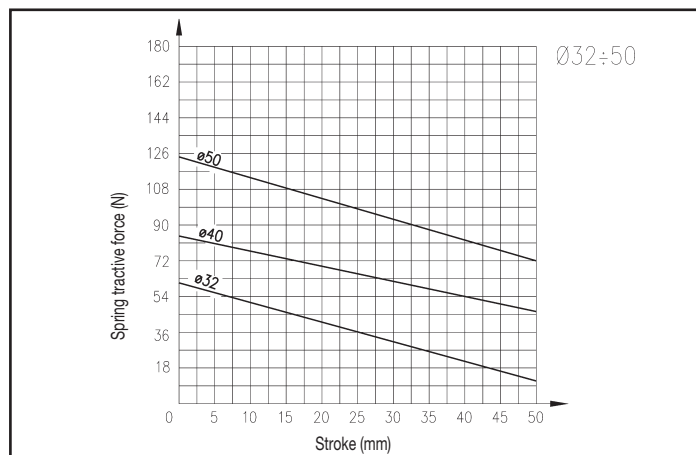
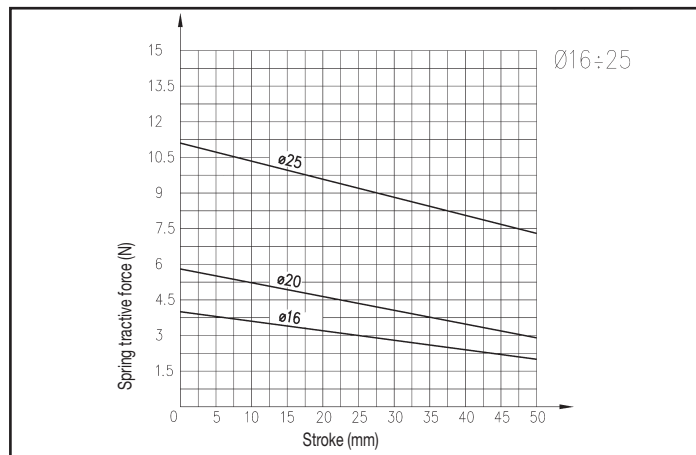

MATERIALS

End caps	Techno-polymer
Cylinder barrel	Extruded tube, AISI 304 stainless steel
Barrel-end cover fixing type	Irreversible calking with dual-seal system, mechanical and pneumatic
Piston rod	AISI 303 rolled stainless steel
Rod, end cap and ring nuts	Stainless steel
Piston	Aluminium alloy with acetal resin piston bearing (supplied with and without magnet)
Seals	Polyurethane
Springs	Steel for springs

ORDER KEY

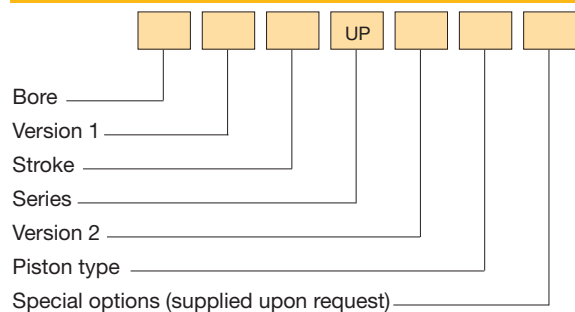

N.B.: *Magnetic sensors* FM 100 - FM157 (see chapter magnetic sensors from page 1.93)
• See technical data on page 0.12

VERSION 1		
/ Basic cylinder	R	Through rod
VERSION 2		
D Double acting	Y	Single acting rear spring*
S Single acting front spring		
PISTON TYPE		
C Non-magnetic	E	Magnetic
OPTION 1		
Z	Fit for piston rod locking unit**	

* Dimension "XC" for version "YE" is increased of 10 mm for $\varnothing 16 \div 25$; for $\varnothing 32 \div 50$ contact our commercial office
** Supplied with $\varnothing 20$ and $\varnothing 25$

ORDER EXAMPLES

Cylinder $\varnothing 20$, through rod, 100 mm stroke, double acting, non-magnetic piston type 20R100 UPDC

Basic cylinder $\varnothing 40$, 50 mm stroke, single acting front spring, non-magnetic piston type 40/50 UPSC

UP BASIC CYLINDER Ø 16 ÷ 25 TO ISO 6432 STANDARD

1

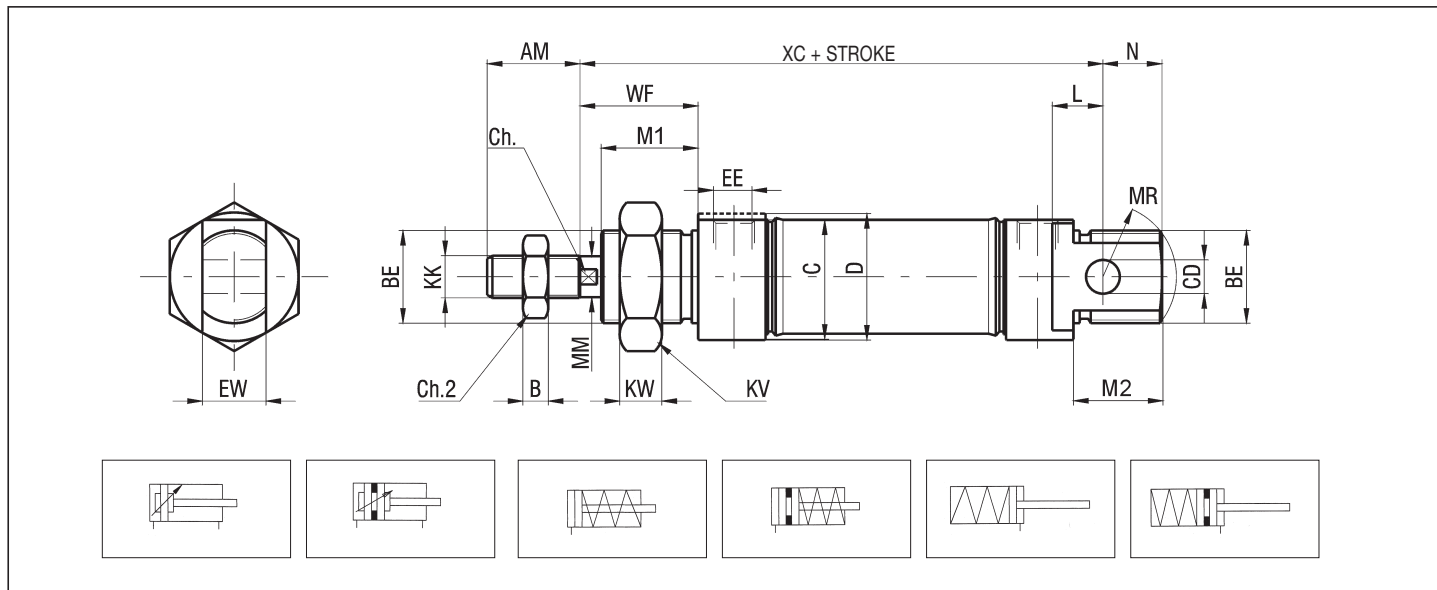

P.S.: End cap nut and rod nut supplied as standard in AISI 304 stainless steel

DIMENSIONS AND WEIGHTS BASIC CYLINDER UP Ø 16 ÷ 25

Ø	AM*	B	BE*	C	CD* H9	Ch*	Ch2	D*	EE*	ES	EW* d13	KK*	KV*	KW*	L*	LB	M1	M2	MM	MR*	N	WB	WF*	XC*	PESO (g)	INCR.(g) x10mm	
16	16	4	M16x1,5	18	6	5	10	21	M5	-	12	M6	24	8	9	77	18	18	6	12	12	-	22	82	▲	63	4,2
20	20	5	M22x1,5	25	8	7	13	26	G 1/8	8	16	M8	30	10	12	91	19	20	8	15	13	71	24	95		138	9,1
25	22	6	M22x1,5	28,5	8	9	17	30	G 1/8	10	16	M10x1,25	30	10	12	100	23	22	10	18	15	73	28	104		188,5	12,5

* STANDARDIZED DIMENSIONS

▲ Dimension "XC" for version "YE" is increased of 10 mm

THROUGH ROD Ø 16 ÷ 25

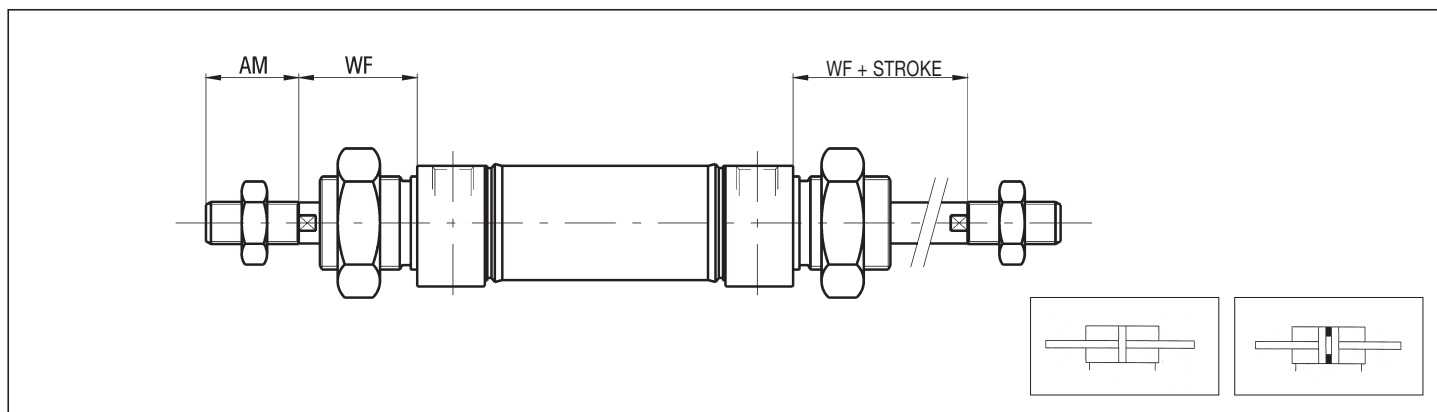

P.S.: End cap nuts and rod nuts supplied as standard in AISI 304 stainless steel

END CAP NUT - STAINLESS STEEL - UPDT Ø

Ø	DI	CH	S	WEIGHT (g)
16	M16x1,5	24	8	16
20-25	M22x1,5	30	10	25

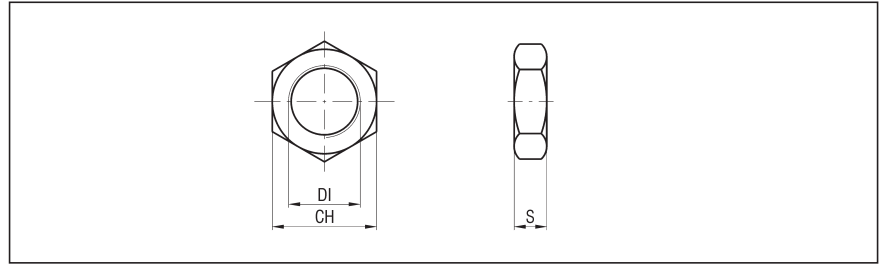

FLANGE - STAINLESS STEEL - UPF Ø

Ø	FB H13	LW	S	TF JS13	UF	UR	WEIGHT (g)
16	5,5	18	4	40	54	30	10
20	6,6	19	5	50	64	36	20
25	6,6	23	5	50	64	36	20

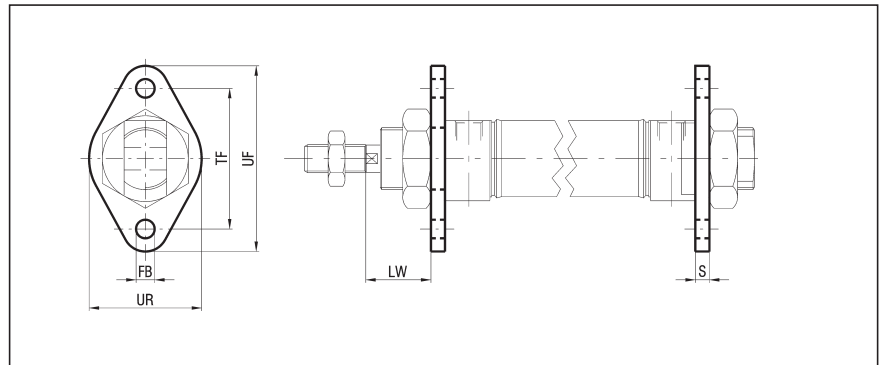

FOOT - STAINLESS STEEL - UPP Ø

Ø	AB H13	AU	LA	LB	LC	NH	R
16	5,5	12	19	74-81	28-35	20	13
20	6,6	13	21,5	91	45,5	25	18
25	6,6	13	21,5	95	45,5	25	18

Ø	S	TR	US	XS	XT	WEIGHT (g)
16	2	32	46	32	10	25
20	2,5	40	54	35	11	40
25	2,5	40	54	39	15	40

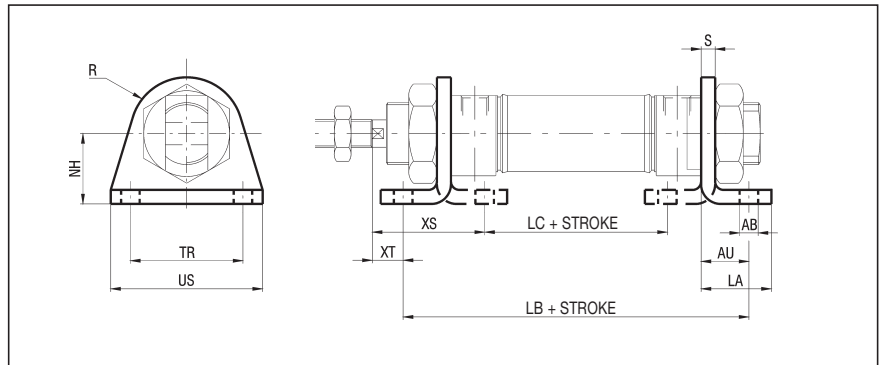

REAR HINGE - STAINLESS STEEL - UPSC Ø

Ø	CD f8	D H13	H	LA	LB	LC E9	LD
16	6	5,5	27	25	15	12,1	5
20	8	6,6	30	32	20	16,1	6
25	8	6,6	30	32	20	16,1	6

Ø	LE	LX	R	S	WEIGHT (g)
16	25	80	7	3	36
20	29,5	91	10	4	78
25	29,5	100	10	4	78

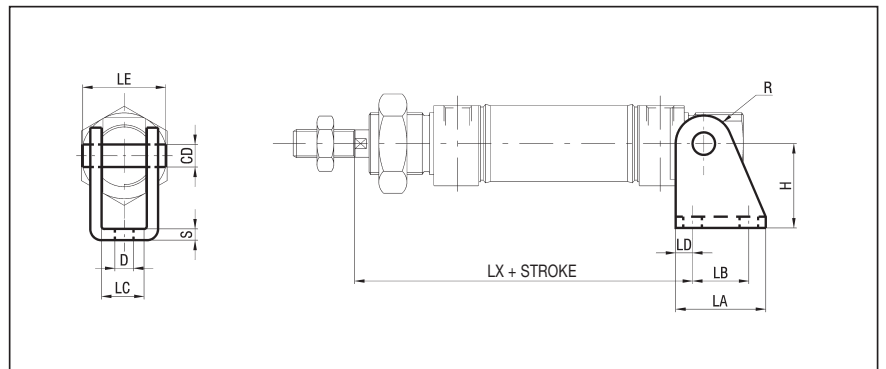

OTHER ACCESSORIES

- Piston rod locking unit series "WBZ" (see page 1.7)
- Guide unit series "WUG" (see page 1.8)

1

UP BASIC CYLINDER Ø 32 ÷ 50

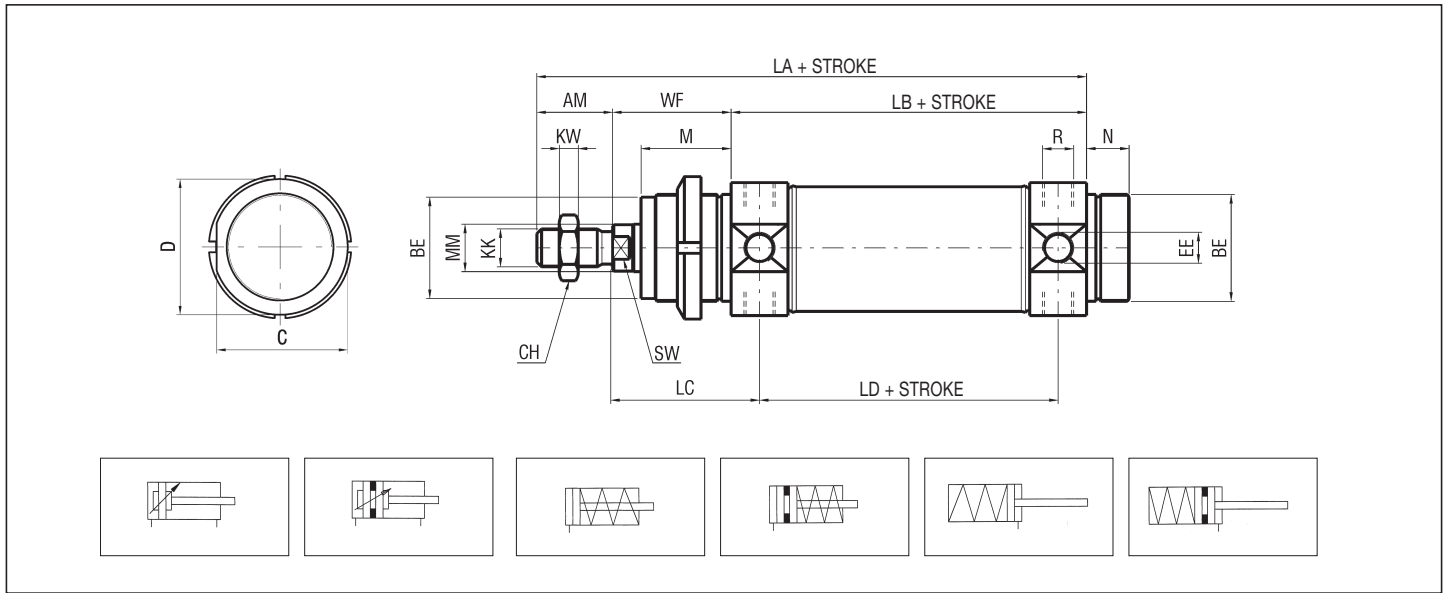

P.S.: End cap ring nut and rod nut supplied as standard in AISI 304 stainless steel

DIMENSIONS AND WEIGHTS BASIC CYLINDER UP Ø 32 ÷ 50

Ø	AM	BE	C	CH	D	EE	KK	KW	LA	LB	LC	LD	M	MM	N	R	SW	WF	XC	WEIGHT (g)	INCR. (g) x 10 mm
32	20	M30x1,5	36,5	17	38	G1/8	M10x1,25	6	154	96	47	78	30	12	14	M8x1	10	38	134	386	16
40	24	M38x1,5	44	19	46	G1/4	M12x1,25	7	182	113	57	89	35	16	16	M10x1	12	45	158	690	26
50	32	M45x1,5	55	24	57	G1/4	M16x1,5	8	202	120	62	96	38	20	18	M12x1,5	16	50	170	1265	34

THROUGH ROD Ø 32 ÷ 50

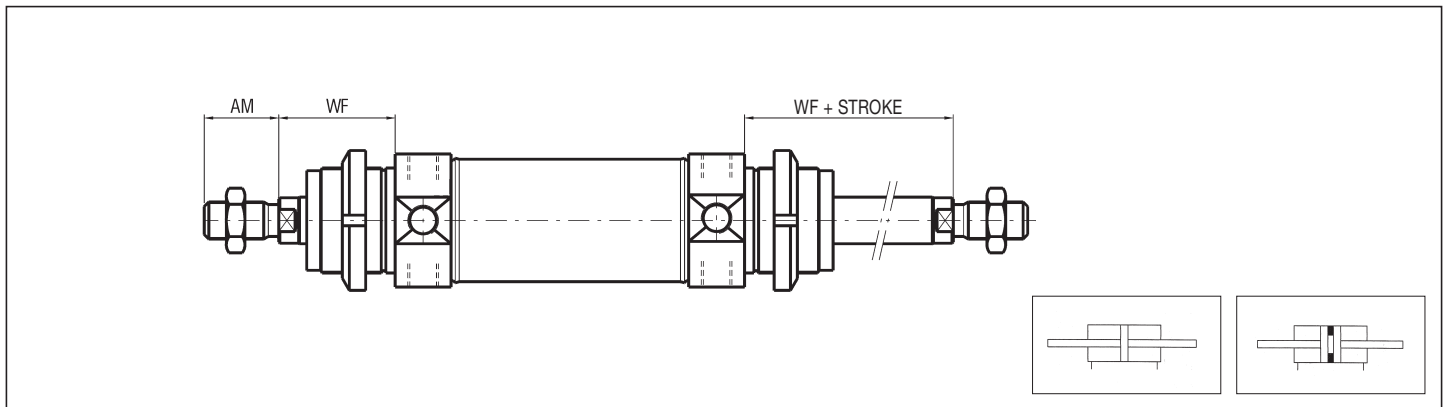

P.S.: End cap ring nuts and rod nuts supplied as standard in AISI 304 stainless steel

Accessories
AISI 304 stainless steel
fixings for round cylinders Ø 32 ÷ 50

series **UP**

1

RING NUT - STAINLESS STEEL - UPG Ø

Ø	d	D	S	WEIGHT (g)
32	M30x1,5	45	7	43
40	M38x1,5	50	8	80
50	M45x1,5	58	9	122

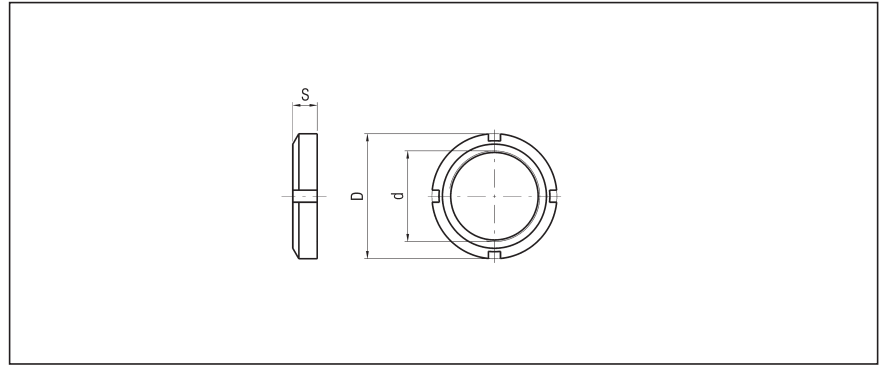

FLANGE/FOOT - STAINLESS STEEL - UPPF Ø

Ø	AB	AU	HA	HB	HC	LA	LB	LC
32	7	14	14	49	28	21	124	76
40	9	20	18	58	30	30	153	83
50	9	20	20	70	40	30	160	92

Ø	NH	S	TB	TR	TS	XS	XT	WEIGHT (g)
32	28	4	14	52	66	48	24	98
40	33	5	20	60	88	60	25	183
50	40	6	20	70	90	64	30	276

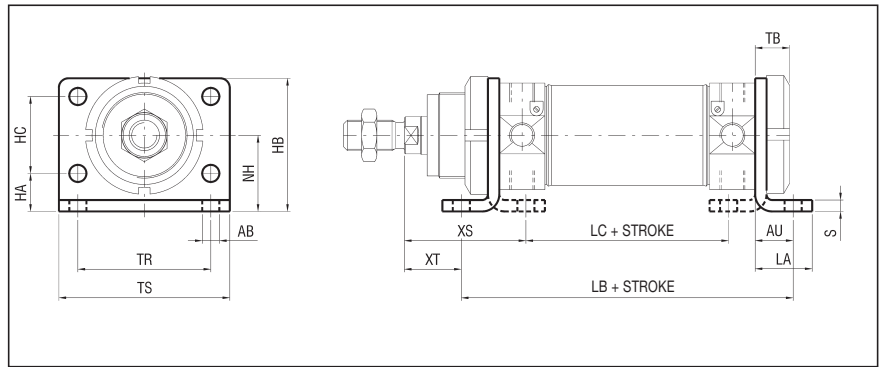

REAR HINGE - STAINLESS STEEL - UPSC Ø

Ø	CH	E	G	H	L	LA	LB
32	13	7	20	35	125	20	46,1
40	17	9,5	27	40	146	28	56,1
50	19	10	30	45	158	36	69,1

Ø	LC	NA	NB	R	S	WEIGHT (g)
32	58	24	40	8	4	150
40	70	30	50	9,5	5	259
50	86	34	54	10	6	403

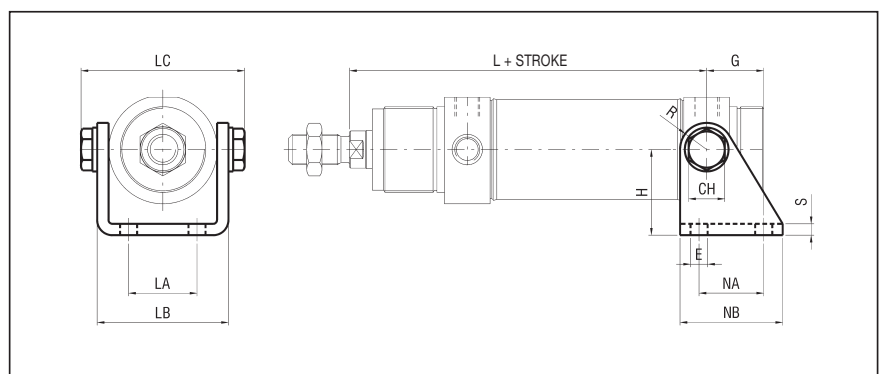

PIVOT (pair) - STAINLESS STEEL - UPT Ø

Ø	D	H	LA	LB	CH	WEIGHT (g)
32	10	51	47	125	5	10
40	12	61	57	146	6	20
50	14	75	62	158	6	40

