

series UDS ISO

Valves to ISO 5599/1 standard pilot and solenoid actuated sizes 1 - 2 - 3

DESCRIPTION

Valves series "UDS ISO" are produced in the 5/2 and 5/3 pneumatic functions according to the interface to ISO 5599/1 standard and they are mounted onto single or manifold bases, bottom or side ported. The ex CNOMO solenoid valve, with manual override (screwdriver type C/UECSVB or button type C/UECSPB), in the solenoid actuated version is mounted with coil type USBG side 30 mm (that allows a greater yield) or type USB side 22 mm.



2

TECHNICAL DATA

Operating pressure	Monostable: 2,5 ÷ 10 bar Bistable: 1,5 ÷ 10 bar
Working temperature	0 ÷ +50 °C (-20 °C with dry air)
Fluid	Filtered, unlubricated or continuous lubricated compressed air
Port size	Interface to ISO 5599/1
Pneumatic piloting port size	Interface to ISO 5599/1
Piloting solenoid valves	C/UECSVB - C/UECSPB - see chapter Direct acting solenoid valves series ex CNOMO on page 2.12
Coils	USBG - see chapter Coils on page 2.14 USB - see chapter Coils on page 2.14
Electric connectors	ULR1B - see chapter Connectors on page 2.15 USR102/N9 - see chapter Connectors on page 2.15

MATERIALS

Bottoms	Size 1 - 2: Techno-polymer Size 3: Aluminium alloy
Body	Size 1 - 2: Techno-polymer Size 3: Aluminium alloy
Distance rings	Acetal resin
Springs	Galvanized steel
Seals	NBR rubber + steel insert
Spool	Aluminium alloy
Piston	Aluminium alloy

SPARE PARTS

SEALS KIT	
Size 1	UDS/SG/105
Size 2	UDS/SG/212
Size 3	UDSI/SG/3

FLOW CHART SIZE 1

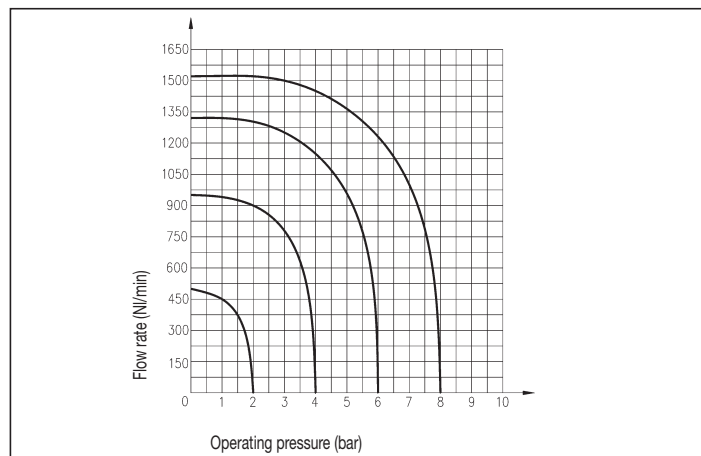

PILOTING CHART SIZE 1

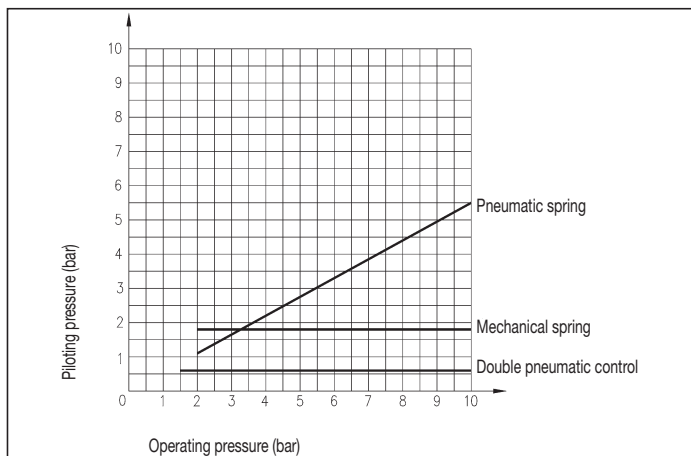

FLOW CHART SIZE 2

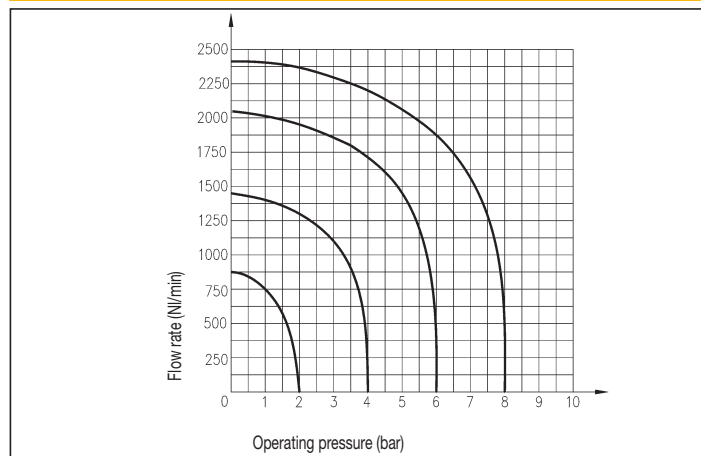

PILOTING CHART SIZE 2

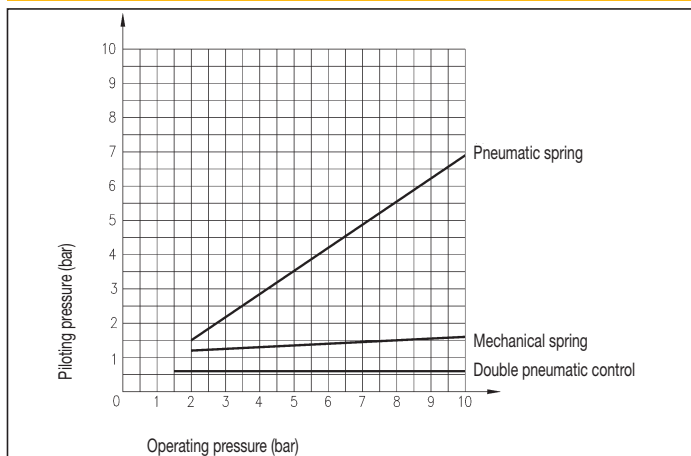

FLOW CHART SIZE 3

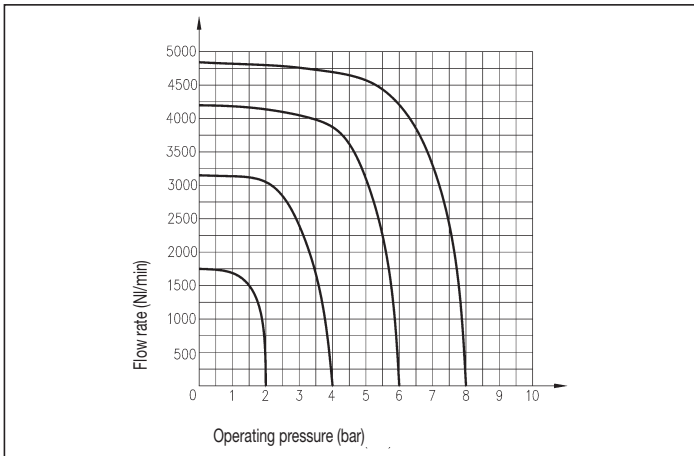

PILOTING CHART SIZE 3

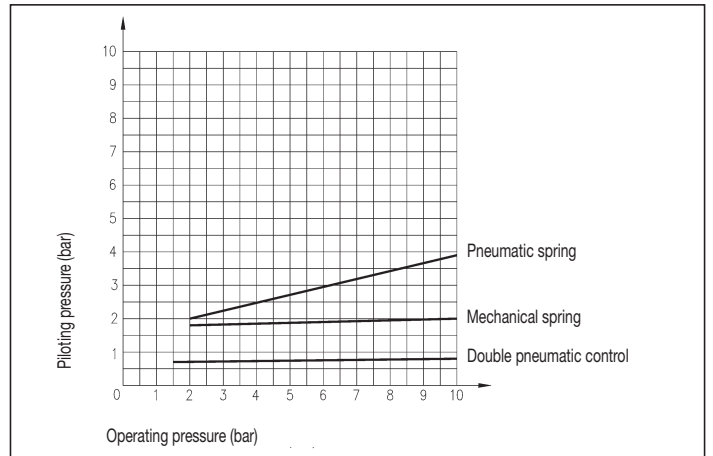

PILOT ACTUATED VALVES SIZE 1

Symbol	Function	Controls		Response times at 6 bar (ms)		Flow rate at 6 bar $\Delta P = 1$ bar (NI/min)	Weight (g)	TYPE
		Actuation	Return	Energized	De-energized			
	5/2 monostable	Pneumatic	Mechanical spring	20	30	960	230	UDS 105 KR/ZR
		Pneumatic	Pneumatic spring	20	14	960	230	UDS 105 KR/TQ
	5/2 bistable	Pneumatic	Pneumatic	15	15	960	230	UDS 105 KR/KR
	5/2 bistable with override on body valve	Pneumatic	Pneumatic	15	15	960	250	UDS 105 KRP/KRP
	5/2 bistable	Pneumatic	Pneumatic differential	15	20	960	230	UDS 105 KR/TR
	5/3 closed centre	Pneumatic	Mechanical spring	20	25	580	275	UDS 105 SR/SR
	5/3 open centre	Pneumatic	Mechanical spring	20	25	800	275	UDS 105 AR/AR
	5/3 pressure centre	Pneumatic	Mechanical spring	20	25	1100	275	UDS 105 PR/PR

5 PORT SIZE 1

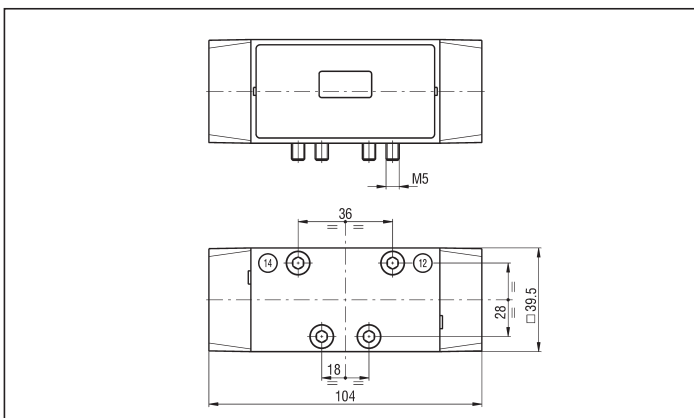

5 PORT SIZE 1 WITH MANUAL OVERRIDE ON BODY VALVE

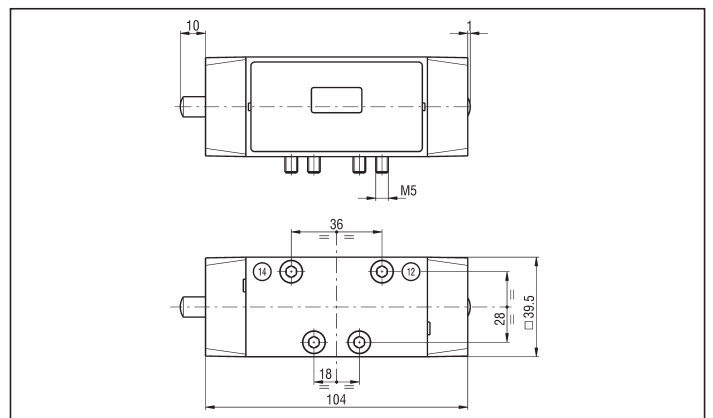

series UDS ISO

2

SOLENOID ACTUATED VALVES SIZE 1

Symbol	Function	Controls		Response time at 6 bar (ms)		Flow rate at 6 bar $\Delta P = 1$ bar (NI/min)	Weight (g)	TYPE*
		Pilot	Return	Energized	De-energized			
	5/2 monostable	Solenoid	Mechanical spring	20	30	960	305	UDS 105 KUEC/ZR
		Solenoid	Pneumatic spring	20	30	960	305	UDS 105 KUEC/TQ
		Solenoid pilot assisted	Mechanical spring	20	30	960	305	UDS 105 KUER/ZR
	5/2 bistable	Solenoid	Small pneumatic	20	25	960	310	UDS 105 KUEC/TR
		Solenoid pilot assisted	Small pneumatic	20	25	960	310	UDS 105 KUER/TR
		Solenoid	Solenoid	15	15	960	375	UDS 105 KUEC/KUEC
		Solenoid pilot assisted	Solenoid pilot assisted	15	15	960	375	UDS 105 KUER/KUER
	5/3 closed centre	Solenoid	Mechanical spring	20	25	580	425	UDS 105 SUEC/SUEC
		Solenoid pilot assisted	Mechanical spring	20	25	580	425	UDS 105 SUER/SUER
	5/3 open centre	Solenoid	Mechanical spring	20	25	800	425	UDS 105 AUEC/AUEC
		Solenoid pilot assisted	Mechanical spring	20	25	800	425	UDS 105 AUER/AUER
	5/3 pressure centre	Solenoid	Mechanical spring	20	25	1100	425	UDS 105 PUEC/PUEC
		Solenoid pilot assisted	Mechanical spring	20	25	1100	425	UDS 105 PUER/PUER

* - SUBSTITUTE THE LETTER "E" WITH THE LETTER "P" IN EACH SOLENOID CONTROL TYPE TO ORDER THE SOLENOID ACTUATED VALVES TO ISO STANDARD WITH MANUAL OVERRIDE (MONOSTABLE BUTTON) ON THE PILOTING SOLENOID VALVES, E.G.: UDS 105 KUEC/TR BECOMES UDS 105 KUPC/TR - UDS 105 KUEC/KUEC BECOMES UDS 105 KUPC/KUPC
 - CANCEL THE LETTER "E" FROM THE TYPE TO ORDER THE SOLENOID ACTUATED VALVES TO ISO STANDARD WITHOUT THE PILOTING SOLENOID VALVES, E.G.: UDS 105 KUEC/ZR BECOMES UDS 105 KUC/ZR
 - THE TYPES OF THE SOLENOID VALVES DO NOT INCLUDE COILS

5 PORT SIZE 1 MONOSTABLE

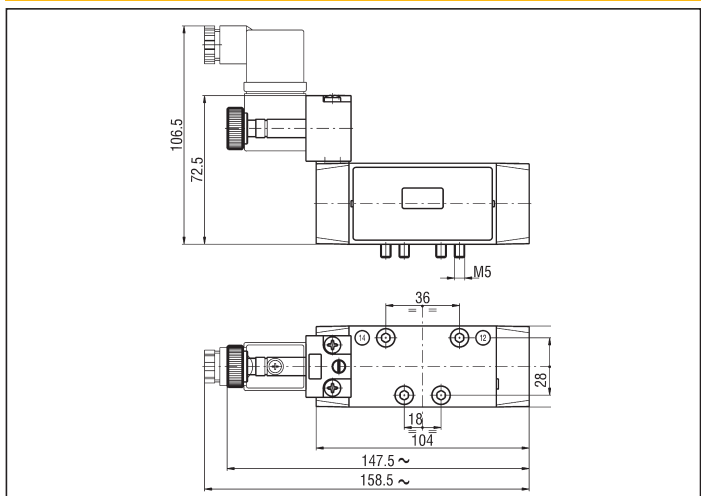

5 PORT SIZE 1 BISTABLE AND 3 POSITIONS

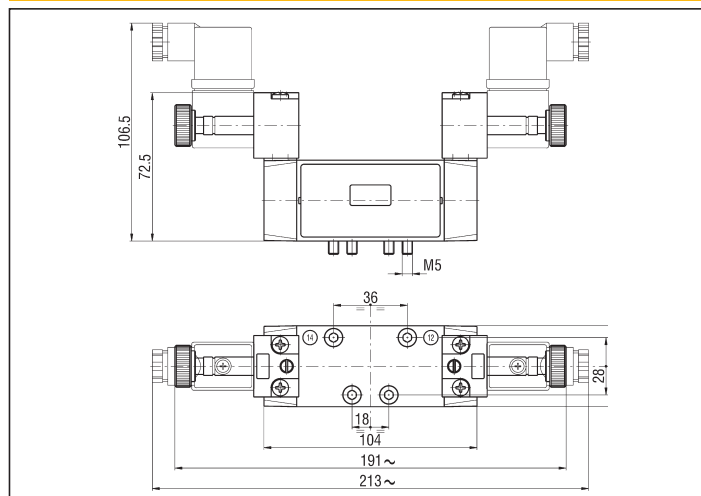

PILOT ACTUATED VALVES SIZE 2

Symbol	Function	Controls		Response time at 6 bar (ms)		Flow rate at 6 bar $\Delta P = 1 \text{ bar (Nl/min)}$	Weight (g)	TYPE
		Pilot	Return	Energized	De-energized			
	5/2 monostable	Pneumatic	Mechanical spring	47	50	1500	515	UDS 212 KR/ZR
		Pneumatic	Pneumatic spring	47	50	1500	510	UDS 212 KR/TQ
	5/2 bistable	Pneumatic	Pneumatic	23	23	1500	515	UDS 212 KR/KR
		Pneumatic	Pneumatic differential	20	40	1500	515	UDS 212 KR/TR
	5/3 closed centre	Pneumatic	Mechanical spring	30	35	1000	580	UDS 212 SR/SR
	5/3 open centre	Pneumatic	Mechanical spring	30	35	1200	580	UDS 212 AR/AR
	5/3 pressure centre	Pneumatic	Mechanical spring	30	35	1300	580	UDS 212 PR/PR

5 PORT SIZE 2

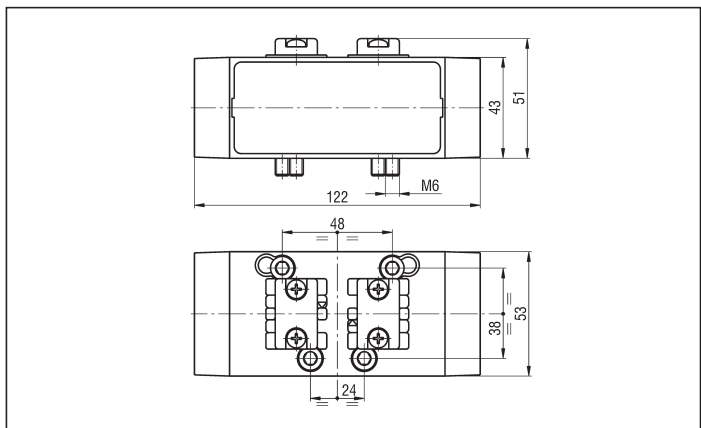

series UDS ISO

2

SOLENOID ACTUATED VALVES SIZE 2

Symbol	Function	Controls		Response time at 6 bar (ms)		Flow rate at 6 bar $\Delta P = 1$ bar (NI/min)	Weight (g)	TYPE*
		Pilot	Return	Energized	De-energized			
	5/2 monostable	Solenoid	Mechanical spring	40	45	1500	580	UDS 212 KUEC/ZR
		Solenoid	Pneumatic spring	47	50	1500	580	UDS 212 KUEC/TQ
		Solenoid pilot assisted	Mechanical spring	40	45	1500	580	UDS 212 KUER/ZR
	5/2 bistable	Solenoid	Small pneumatic	40	45	1500	580	UDS 212 KUEC/TR
		Solenoid pilot assisted	Small pneumatic	40	45	1500	580	UDS 212 KUER/TR
		Solenoid	Solenoid	20	20	1500	635	UDS 212 KUEC/KUEC
		Solenoid pilot assisted	Solenoid pilot assisted	20	20	1500	635	UDS 212 KUER/KUER
	5/3 closed centre	Solenoid	Mechanical spring	30	35	1000	720	UDS 212 SUEC/SUEC
		Solenoid pilot assisted	Mechanical spring	30	35	1000	720	UDS 212 SUER/SUER
	5/3 open centre	Solenoid	Mechanical spring	30	35	1200	720	UDS 212 AUEC/AUEC
		Solenoid pilot assisted	Mechanical spring	30	35	1200	720	UDS 212 AUER/AUER
	5/3 pressure centre	Solenoid	Mechanical spring	30	35	1300	720	UDS 212 PUEC/PUEC
		Solenoid pilot assisted	Mechanical spring	30	35	1300	720	UDS 212 PUER/PUER

* - SUBSTITUTE THE LETTER "E" WITH THE LETTER "P" IN EACH SOLENOID CONTROL TYPE TO ORDER THE SOLENOID ACTUATED VALVES TO ISO STANDARD WITH MANUAL OVERRIDE (MONOSTABLE BUTTON) ON THE PILOTING SOLENOID VALVES, E.G.: UDS 212 KUEC/TR BECOMES UDS 212 KUPC/TR - UDS 212 KUEC/KUEC BECOMES UDS 212 KUPC/KUPC
 - CANCEL THE LETTER "E" FROM THE TYPE TO ORDER THE SOLENOID ACTUATED VALVES TO ISO STANDARD WITHOUT THE PILOTING SOLENOID VALVES, E.G.: UDS 212 KUEC/ZR BECOMES UDS 212 KUC/ZR
 - THE TYPES OF THE SOLENOID VALVES DO NOT INCLUDE COILS

5 PORT SIZE 2 MONOSTABLE

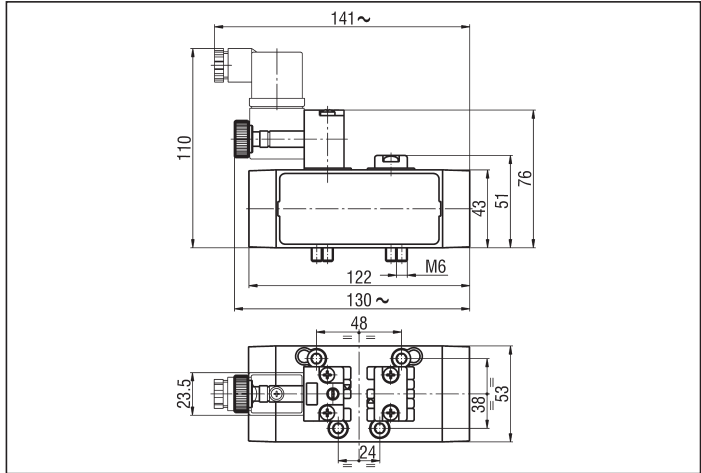

5 PORT SIZE 2 BISTABLE AND 3 POSITIONS

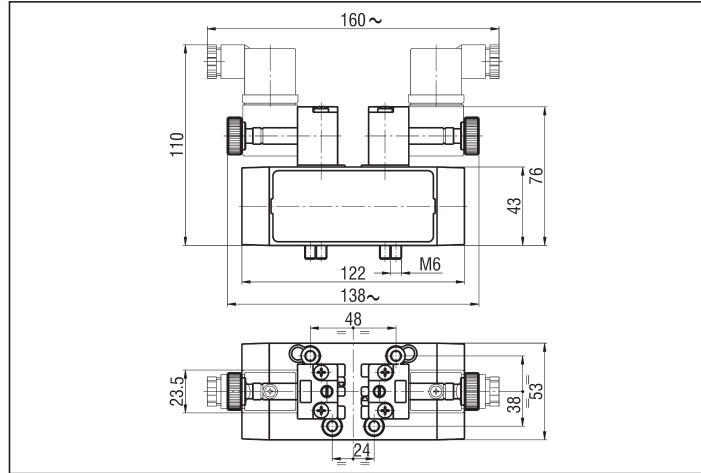

PILOT ACTUATED VALVES SIZE 3

Symbol	Function	Controls		Response time at 6 bar (ms)		Flow rate at 6 bar $\Delta P = 1 \text{ bar (Nl/min)}$	Weight (g)	TYPE
		Pilot	Return	Energized	De-energized			
	5/2 monostable	Pneumatic	Mechanical spring	38	42	3000	1995	UDSI 3 KR/ZR
		Pneumatic	Pneumatic spring	38	42	3000	1985	UDSI 3 KR/TQ
	5/2 bistable	Pneumatic	Pneumatic	28	28	3000	1965	UDSI 3 KR/KR
		Pneumatic	Pneumatic differential	28	35	3000	1965	UDSI 3 KR/TR
	5/3 closed centre	Pneumatic	Mechanical spring	27	32	2900	2020	UDSI 3 SR/SR
	5/3 open centre	Pneumatic	Mechanical spring	27	32	3000	2020	UDSI 3 AR/AR

5 PORT SIZE 3

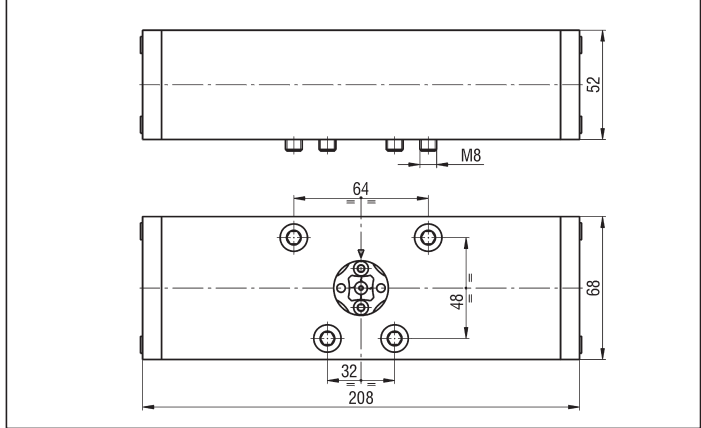

SOLENOID ACTUATED VALVES SIZE 3

Symbol	Function	Controls		Response time at 6 bar (ms)		Flow rate at 6 bar $\Delta P = 1$ bar (NI/min)	Weight (g)	TYPE*
		Pilot	Return	Energized	De-energized			
	5/2 monostable	Solenoid	Mechanical spring	40	42	3100	2120	UDSI 3 KUEC/ZR
		Solenoid	Pneumatic spring	40	42	3100	2120	UDSI 3 KUEC/TQ
		Solenoid pilot assisted	Mechanical spring	40	42	3100	2120	UDSI 3 KUER/ZR
	5/2 bistable	Solenoid	Small pneumatic	40	45	3100	2120	UDSI 3 KUEC/TR
		Solenoid pilot assisted	Small pneumatic	40	45	3100	2120	UDSI 3 KUER/TR
		Solenoid	Solenoid	28	28	3100	2180	UDSI 3 KUEC/KUEC
		Solenoid pilot assisted	Solenoid pilot assisted	28	28	3100	2180	UDSI 3 KUER/KUER
	5/3 closed centre	Solenoid	Mechanical spring	27	32	2900	2180	UDSI 3 SUEC/SUEC
		Solenoid pilot assisted	Mechanical spring	27	32	2900	2180	UDSI 3 SUER/SUER
	5/3 open centre	Solenoid	Mechanical spring	27	32	3000	2180	UDSI 3 AUEC/AUEC
		Solenoid pilot assisted	Mechanical spring	27	32	3000	2180	UDSI 3 AUER/AUER

* - SUBSTITUTE THE LETTER "E" WITH THE LETTER "P" IN EACH SOLENOID CONTROL TYPE TO ORDER THE SOLENOID ACTUATED VALVES TO ISO STANDARD WITH MANUAL OVERRIDE (MONOSTABLE BUTTON) ON THE PILOTING SOLENOID VALVES, E.G.: UDSI 3 KUEC/TR BECOMES UDSI 3 KUPC/TR - UDSI 3 KUEC/KUEC BECOMES UDSI 3 KUPC/KUPC
 - CANCEL THE LETTER "E" FROM THE TYPE TO ORDER THE SOLENOID ACTUATED VALVES TO ISO STANDARD WITHOUT THE PILOTING SOLENOID VALVES, E.G.: UDSI 3 KUEC/ZR BECOMES UDSI 3 KUC/ZR - THE TYPES OF THE SOLENOID VALVES DO NOT INCLUDE COILS

5 PORT SIZE 3 MONOSTABLE

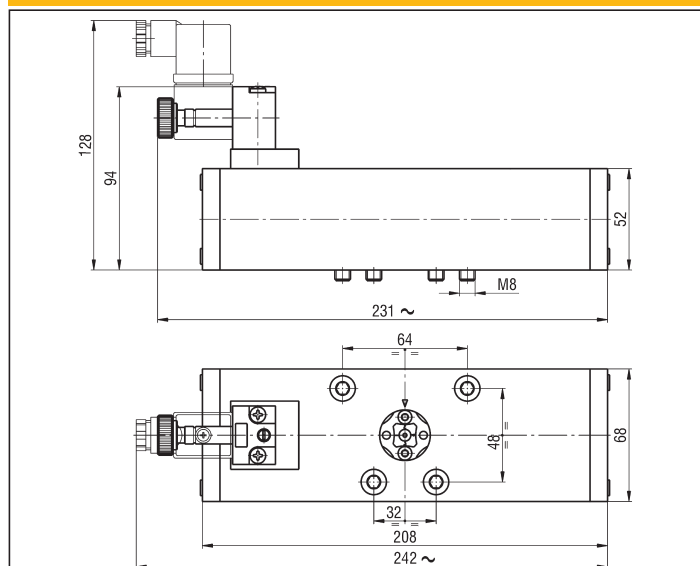

5 PORT SIZE 3 BISTABLE E 3 POSITIONS

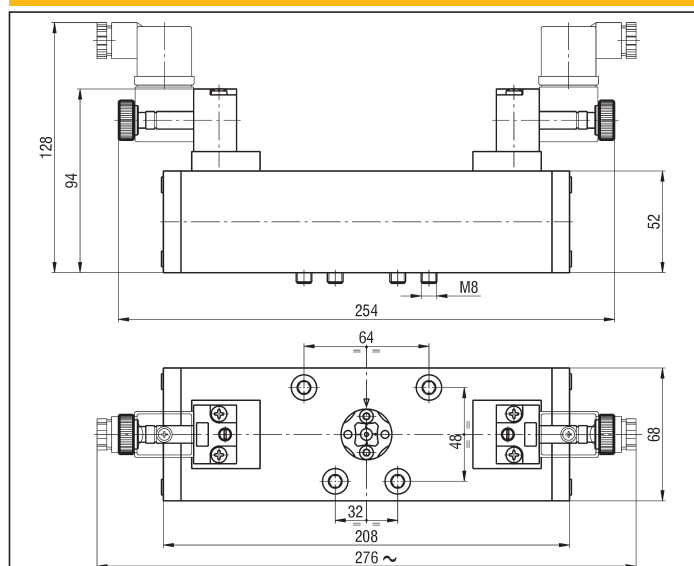

SINGLE BASE SIDE PORTED - UDP/ISO SIZE /S

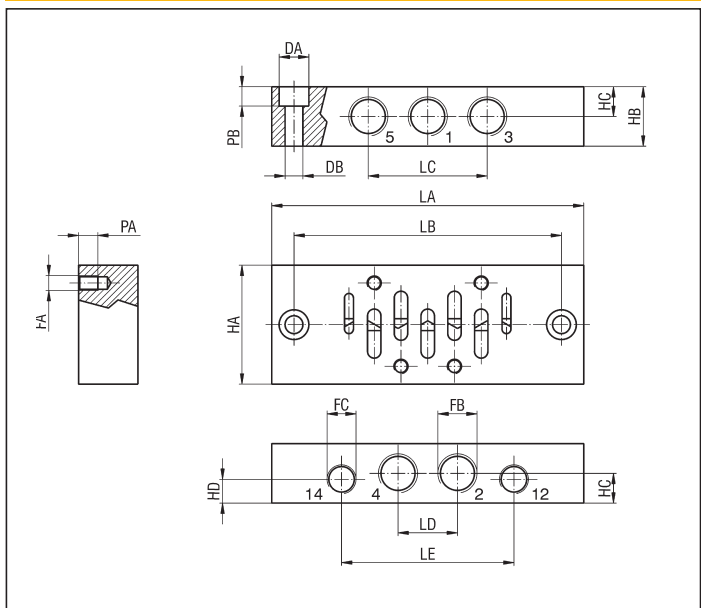

TYPE	UDP/ISO1/S8	UDP/ISO1/S4	UDP/ISO2/S4	UDP/ISO2/S3	UDP/ISO3/S2
Weight (g)	205	240	485	455	1090
SIZE	1		2		3
DA	10	10	12	12	15
DB	6	6	7	7	9
FA	M5	M5	M6	M6	M8
FB	G 1/8	G 1/4	G 1/4	G 3/8	G 1/2
FC	G 1/8	G 1/8	G 1/8	G 1/8	G 1/8
HA	40	40	55	55	70
HB	20	25	28	28	32
HC	8	14,5	13	15	16
HD	8	8	8	8	8
LA	105	105	130	130	208
LB	90	90	110	110	180
LC	36	40	48	52	64
LD	18	20	24	26	32
LE	58	58	68	70	90
PA	6,5	6,5	10	10	10
PB	6,5	6,5	8	8	11

SINGLE BASE BOTTOM PORTED - UDP/ISO SIZE /B

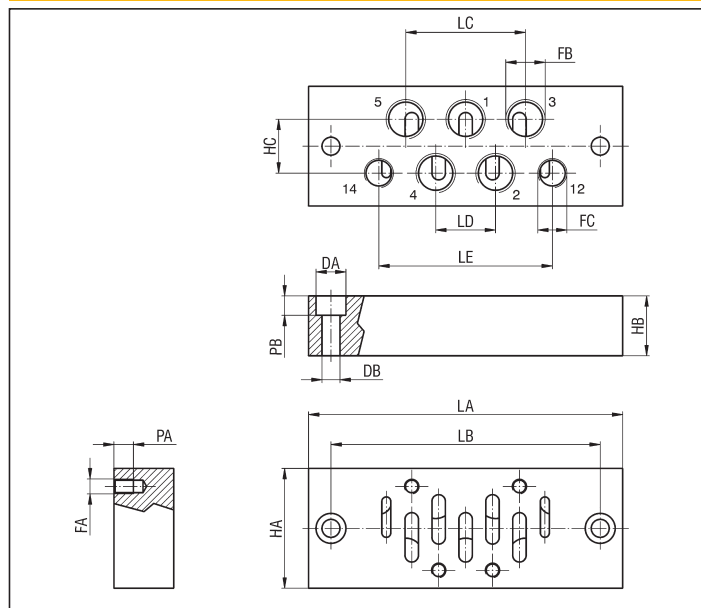

TYPE	UDP/ISO1/B8	UDP/ISO1/B4	UDP/ISO2/B4	UDP/ISO2/B3	UDP/ISO3/B2
Weight (g)	200	190	495	470	1160
SIZE	1		2		3
DA	10	10	12	12	15
DB	6	6	7	7	9
FA	M5	M5	M6	M6	M8
FB	G 1/8	G 1/4	G 1/4	G 3/8	G 1/2
FC	G 1/8	G 1/8	G 1/8	G 1/8	G 1/8
HA	40	40	55	55	70
HB	20	20	28	28	32
HC	16	18	22	23	27
LA	105	105	130	130	208
LB	90	90	110	110	180
LC	36	40	48	52	64
LD	18	20	24	26	32
LE	58	58	68	70	90
PA	8	8	10	10	10
PB	6,5	6,5	8	8	11

series UDS ISO

Manifold bases to ISO 5599/1
standard sizes 1-2-3
obtained from drawn light alloy

2

MANIFOLD BASE SIDE PORTED - UDP/ISO SIZE /MS/Q

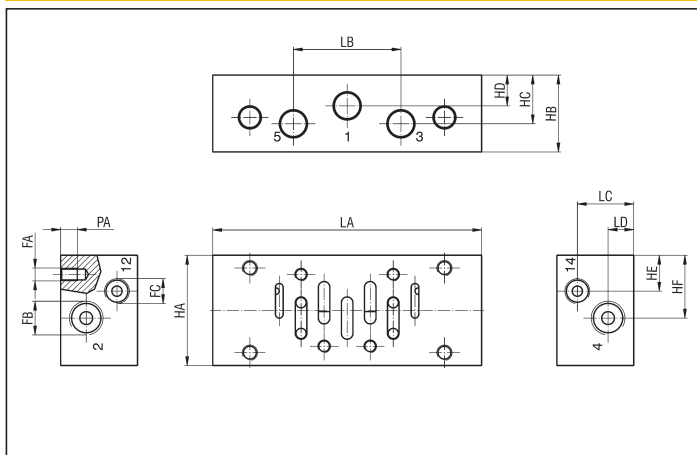

TYPE	UDP/ISO1/8MS/Q	UDP/ISO1/4MS/Q	UDP/ISO2/3MS/Q
Weight (g)	320	310	660
SIZE	ISO 1		ISO 2
FA	M5	M5	M6
FB	G 1/8	G 1/4	G 3/8
FC	G 1/8	G 1/8	G 1/8
HA	43	43	55
HB	30	30	40
HC	19	19	24
HD	12	12	17
HE	14	14	17,5
HF	24,5	24,5	30
LA	105	105	130
LB	42	42	54
LC	22	22	30
LD	10	10	12,5
PA	6,5	6,5	8

MANIFOLD BASE BOTTOM PORTED - UDP/ISO SIZE M/Q

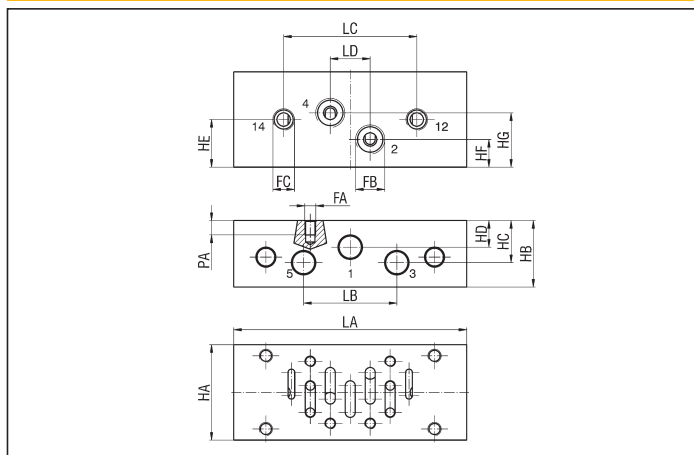

TYPE	UDP/ISO1/8M/Q	UDP/ISO1/4M/Q	UDP/ISO2/3M/Q	UDP/ISO3/2M/Q
Weight (g)	320	315	665	1640
SIZE	ISO 1		ISO 2	ISO 3
FA	M5	M5	M6	M8
FB	G 1/8	G 1/4	G 3/8	G 1/2
FC	G 1/8	G 1/8	G 1/8	G 1/8
HA	43	43	55	70
HB	30	30	40	50
HC	19	19	24	27
HD	12	12	17	27
HE	21,5	21,5	27,5	35
HF	12,5	12,5	16,5	23,5
HG	24,5	24,5	32,5	42,5
LA	105	105	130	208
LB	42	42	54	88
LC	60	60	74	125
LD	18	18	24	42
PA	6,5	6,5	8	10

INPUT PLATES (pair) - UDP/ISO SIZE /...M/L

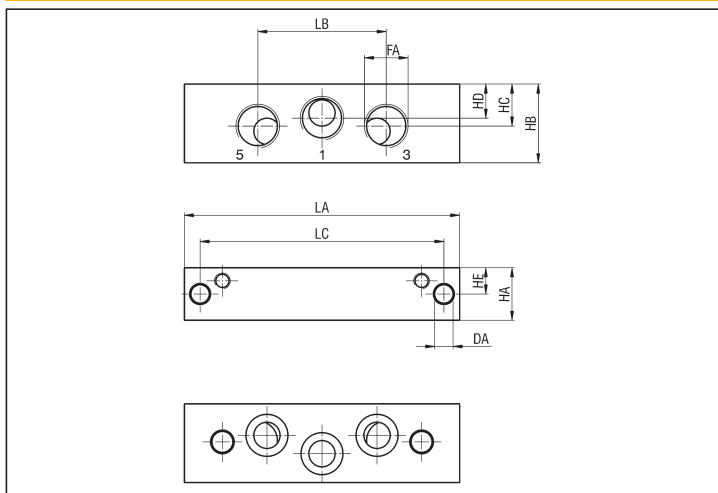

TYPE	UDP/ISO1/3M/L	UDP/ISO2/2M/L	UDP/ISO3/1M/L
Weight (g)	280	460	2355
SIZE	ISO 1	ISO 2	ISO 3
DA	7	7	9
FA	G 3/8	G 1/2	G 1
HA	20	20	50
HB	30	40	50
HC	16	22	25
HD	13	15	25
HE	10	10	25
LA	105	130	208
LB	49	59	94
LC	93	118	180

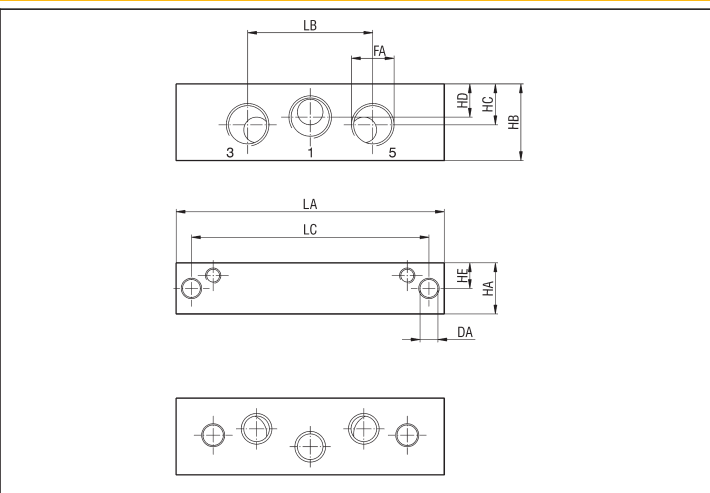

BLANKING PLATE ISO 1 - UDP/ISO1/PC

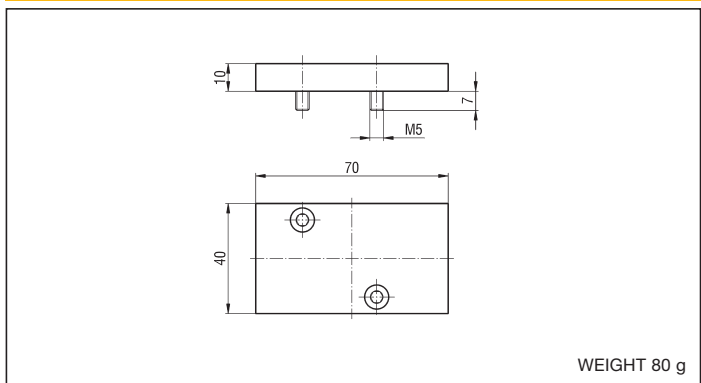

BLANKING PLATE ISO 2 - UDP/ISO2/PC

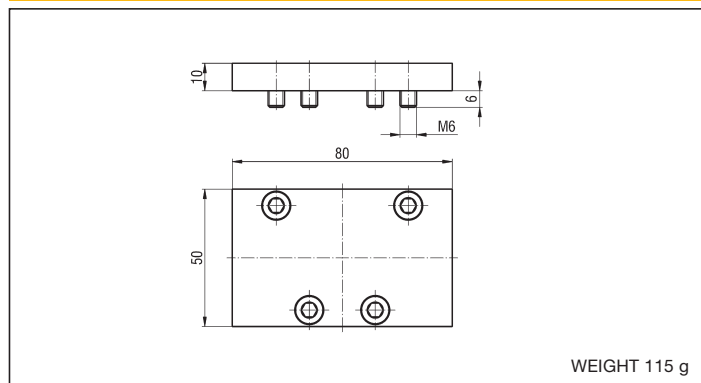

SIZE ADAPTER ISO 1-2 AND ISO 2-3 - UDP/ISO SIZE

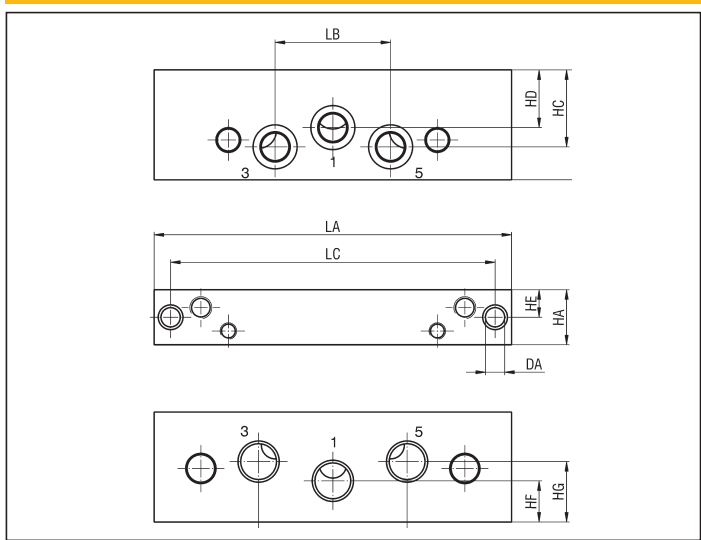

TYPE	UDP/ISO1-2	UDP/ISO2-3
Weight (g)	245	1305
SIZE	1-2	2-3
DA	7	9
HA	20	50
HB	40	50
HC	28	32
HD	21	35
HE	10	25
HF	15	25
HG	22	25
LA	130	208
LB	42	54
LC	118	180
LD	54	88

KIT ASSEMBLY BASES

Kit assembly bases ISO 1	KIT/UDP/ISO 1
Kit assembly bases ISO 2	KIT/UDP/ISO 2
Kit assembly bases ISO 3	KIT/UDP/ISO 3

DIAPHRAGM - UDP/ISO SIZE /T

TYPE	UDP/ISO1/T	UDP/ISO2/T	UDP/ISO3/T
SIZE	1	2	3

EXAMPLE OF ASSEMBLY

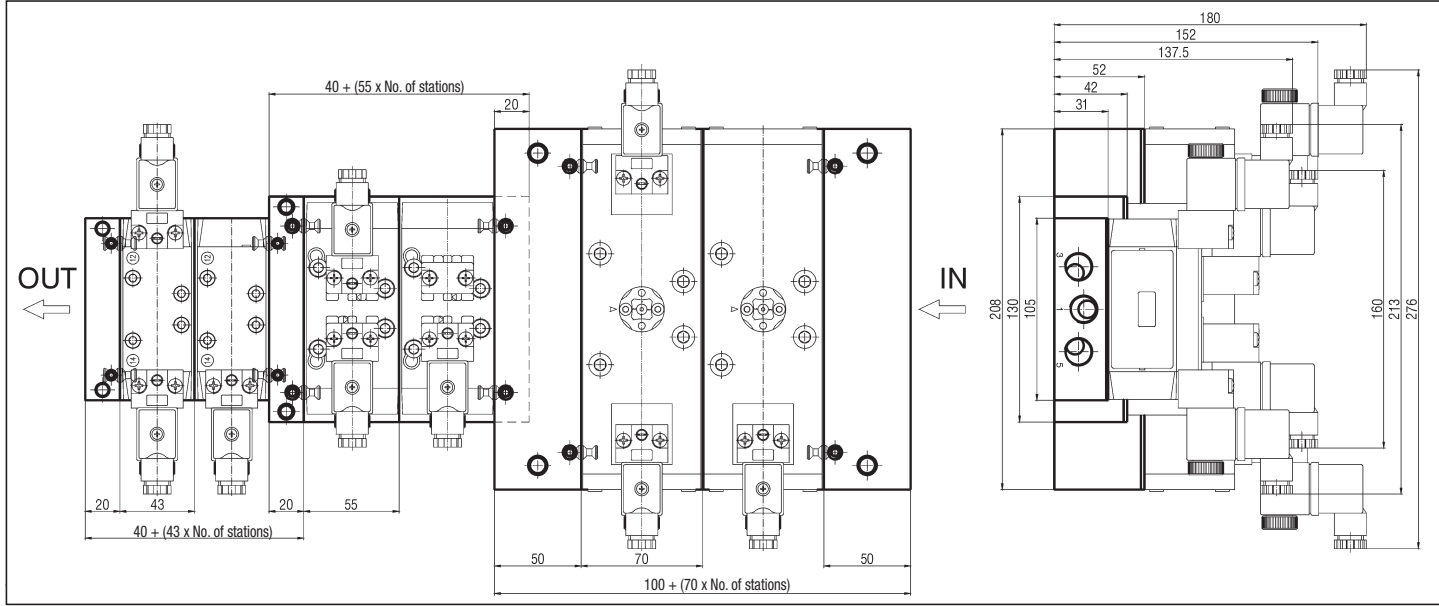

series UDS ISO

2

INPUT PLATE - UDP/ISO1PE

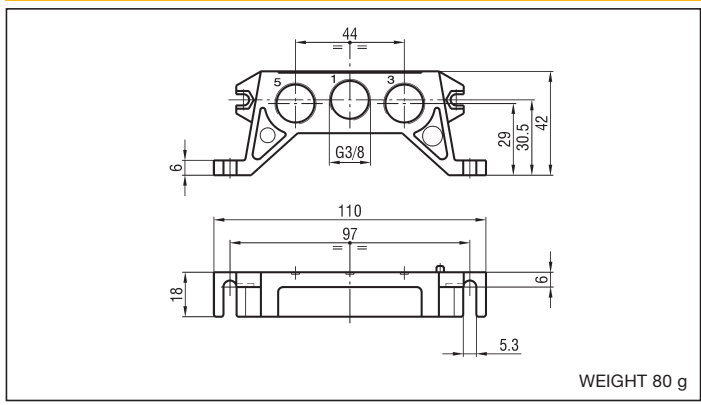

WEIGHT 80 g

INPUT PLATE IS SUPPLIED COMPLETE WITH SCREWS AND SEALS

BLIND TERMINAL PLATE - UDP/ISO1PT

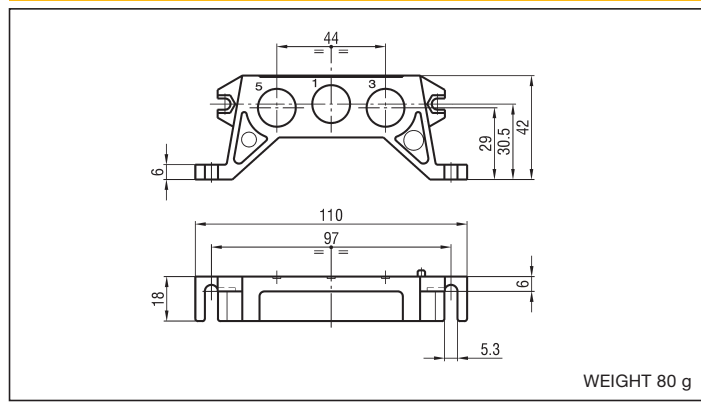

WEIGHT 80 g

UNIVERSAL PLATE

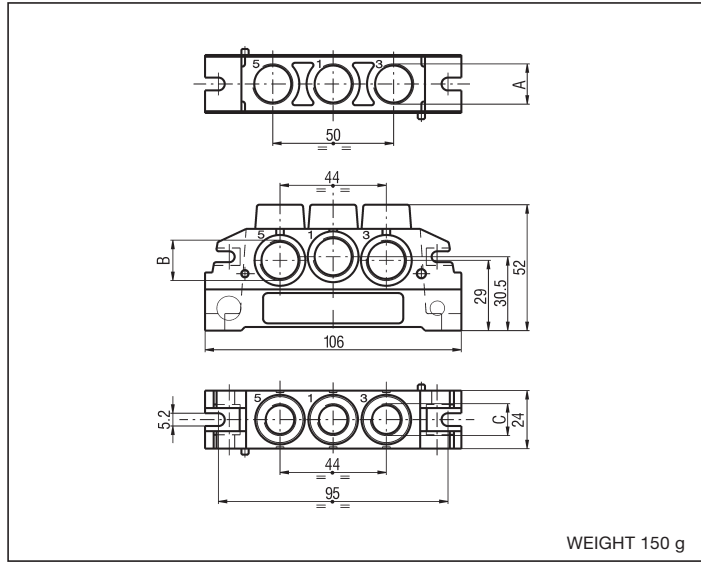

WEIGHT 150 g

DESCRIPTION	A	B	C	TYPE
Intermediate plate, bottom ported	G 3/8	-	-	UDP/ISO1PUI
Intermediate plate, side ported	-	G 3/8	-	UDP/ISO1PUL
Intermediate plate, top ported	-	-	G 1/4	UDP/ISO1PUS
Intermediate plate with blind holes	G 3/8	G 3/8	G 1/4	UDP/ISO1PU

PLATES ARE SUPPLIED COMPLETE WITH SCREWS AND SEALS

MANIFOLD BASE, SIDE AND BOTTOM PORTED - UDP/ISO1BM

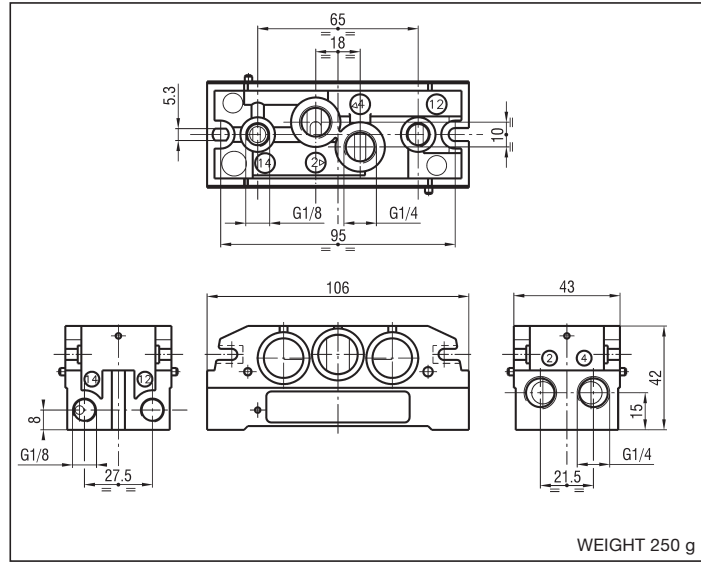

WEIGHT 250 g

MANIFOLD BASE IS SUPPLIED COMPLETE WITH SCREWS, SEALS AND PLUGS (USE A FLUID SEAL)

DIAPHRAGM - UDP/ISO1D

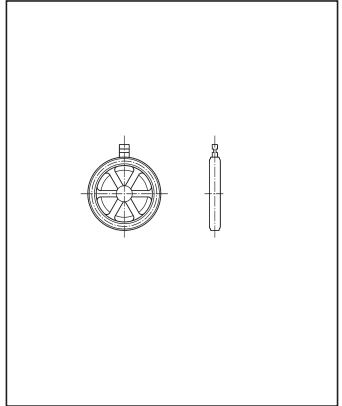

DIAPHRAGM - UDP/ISO2D

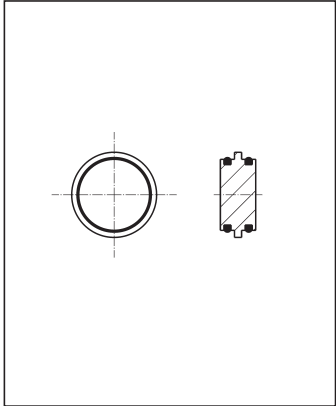

SIZE ADAPTER ISO 1-2 - UDP/ISODT1-2

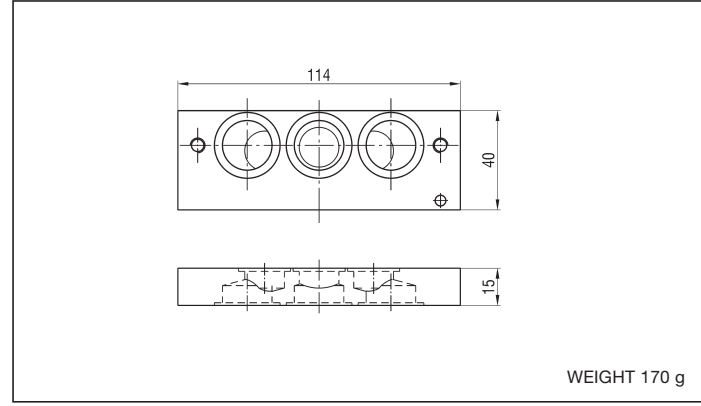

WEIGHT 170 g

SIZE ADAPTER IS SUPPLIED COMPLETE WITH SCREWS AND SEALS

INPUT PLATE - UDP/ISO2PE

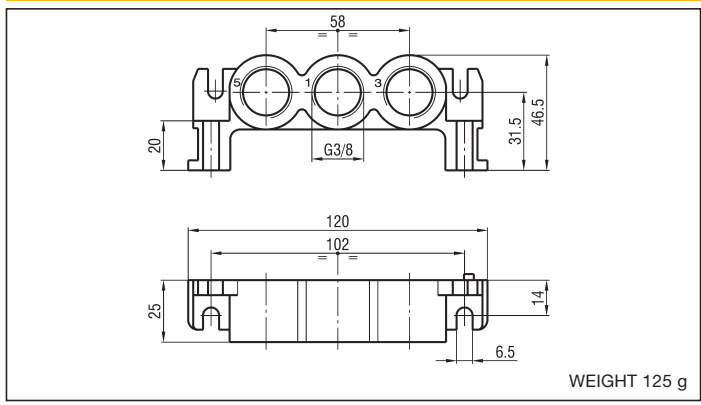

WEIGHT 125 g

INPUT PLATE IS SUPPLIED COMPLETE WITH SCREWS AND SEALS

BLIND TERMINAL PLATE - UDP/ISO2PT

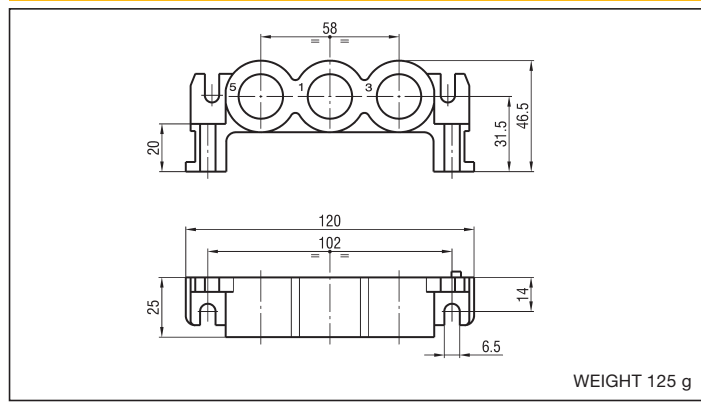

WEIGHT 125 g

UNIVERSAL PLATE

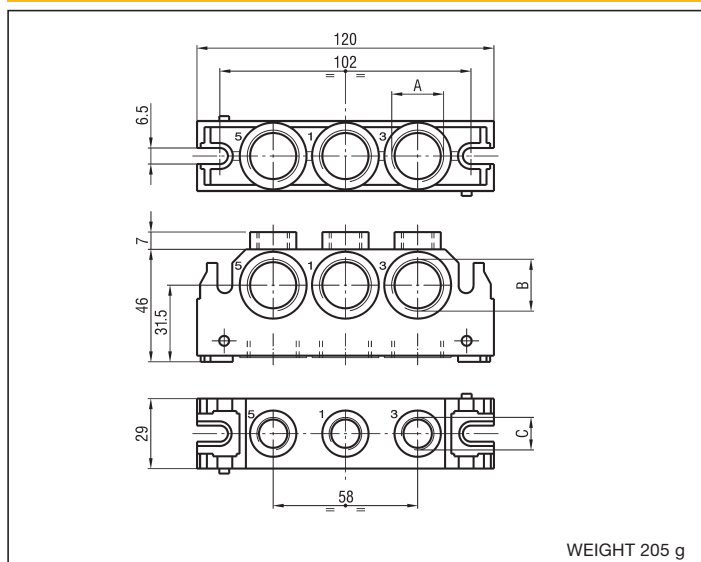

WEIGHT 205 g

DESCRIPTION	A	B	C	TYPE
Intermediate plate, bottom ported	G 1/2	-	-	UDP/ISO2PUI
Intermediate plate, side ported	-	G 1/2	-	UDP/ISO2PUL
Intermediate plate, top ported	-	-	G 1/4	UDP/ISO2PUS
Intermediate plate with blind holes	G 1/2	G 1/2	G 1/4	UDP/ISO2PU

PLATES ARE SUPPLIED COMPLETE WITH SCREWS AND SEALS

MANIFOLD BASE, SIDE AND BOTTOM PORTED - UDP/ISO2BM

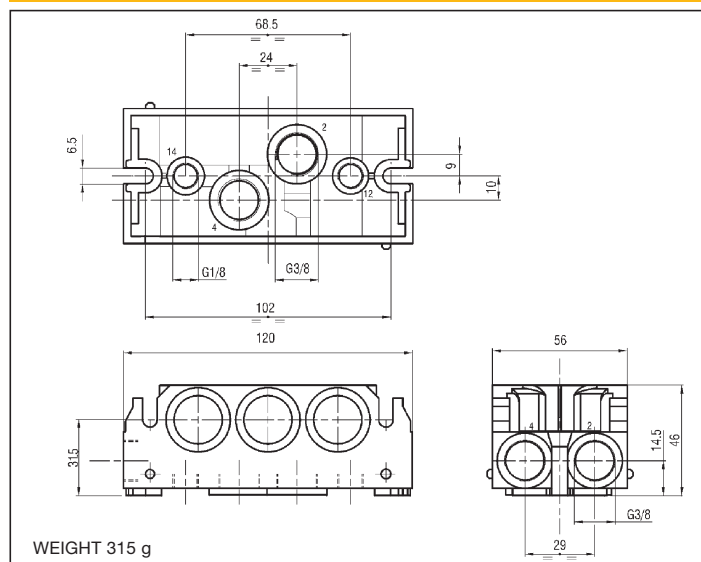

WEIGHT 315 g

MANIFOLD BASE IS SUPPLIED COMPLETE WITH SCREWS, SEALS AND PLUGS (USE A FLUID SEAL)

EXAMPLE OF ASSEMBLY

